

# VELOBLEND MVP SERIES

Advanced Liquid Polymer Activation Technologies

*The result of over 30 years pursuing optimum polymer performance and system reliability.*

## AS IT TURNS OUT, IT IS POSSIBLE TO PATENT “AND”

While the rest of the polymer equipment industry was engaged in a mechanical versus non-mechanical system debate, VeloDyne developed the next generation of advanced polymer activation technologies, a hybrid of the two approaches:

The VeloBlend's first stage perfects the use of hydro-dynamic, non-mechanical mixing energy, while the second hydro-mechanical stage eliminates the biggest drawback to non-mechanical blending—its reliance on water pressure. The VeloBlend™ hybrid polymer activation technology combines the reliability of hydro-dynamic, non-mechanical mixing energy with controllable, variable speed hydro-mechanical mixing energy to provide precise control of mixing conditions, allowing optimal performance of any polymer available.

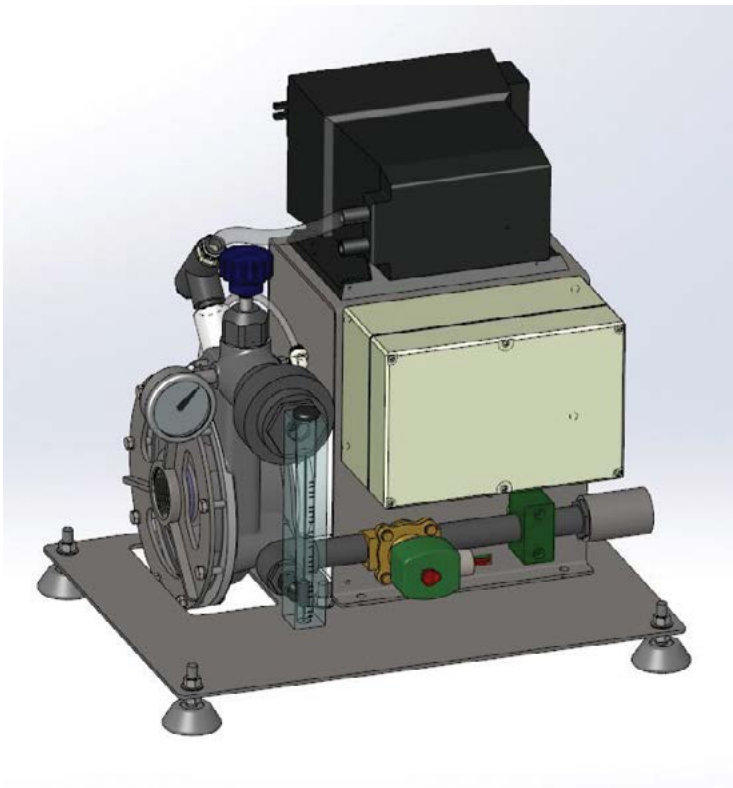

VELDYNE

*A company driven to deliver the very best Polymer Blending, Chemical Feed, and Bulk Solids Handling Systems, fueled by constantly asking, “What If?”*

# VELOBLEND MVP SERIES

Advanced Liquid Polymer Activation Technologies

## VELOBLEND SYSTEM DIMENSIONS

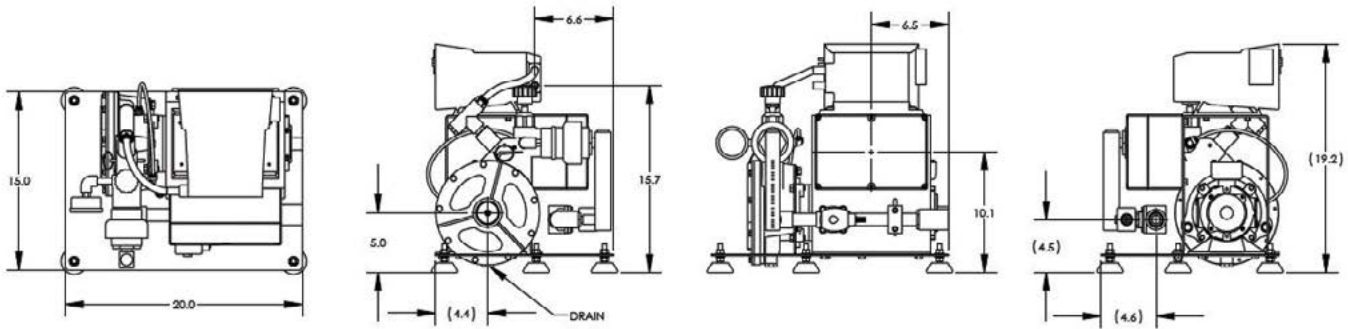

### Select Your VeloBlend Model:

SERIES	NOMINAL POLYMER RANGE GPH*	WATER RANGE SELECTION GPM
MVP-0.5PS-60	0.05 to 0.5	0.1 to 1
MVP-1PS-120	0.1 to 1	0.2 to 2
MVP-2PS-300	0.2 to 2	0.5 to 5
MVP-4PS-600	0.4 to 4	1 to 10

\*Note: Peristaltic pump rates based on nominal catalog specifications and may be reduced due to polymer viscosity, pump suction conditions and or discharge pressures.

### KEY FEATURES & BENEFITS:

- Hybrid, hydro-mechanical activation technology
  - Non-mechanical mixing energy blends & activates polymer with water pressure as low as 30 psiD
  - Variable intensity, controllable mixing energy available to optimize polymer activation independent of water pressure or flow
- Quick-access, reliable check valve
- Stainless steel mixing chamber with clear cover
- Compact Stainless Steel Skid
- Optional Wall Mounting Shelf
- Controls:
  - Local Start / Stop
  - Remote Start / Stop
  - Variable Mixing Energy Control
  - 4-20mA Metering Pump Pacing



VeloDyneSystems.com



© 2018 Velocity Dynamics, LLC. All rights reserved. Results may vary under different operating conditions. Specifications, terms and pricing are subject to change. Please consult your local sales representative for details. VeloDyne.1015.0918

Phone: 303-530-3298  
E-Mail: Sales@VeloDyneSystems.com